

CBCS SCHEME

USN

--	--	--	--	--	--	--	--	--	--

21EC43

Fourth Semester B.E. Degree Examination, Dec.2023/Jan.2024

Circuits and Controls

Time: 3 hrs.

Max. Marks: 100

Note: Answer any FIVE full questions, choosing ONE full question from each module.

Module-1

- 1 a. Find the power delivered to $4\ \Omega$ Resistor shown in Fig. Q1 (a) using mesh analysis.

(07 Marks)

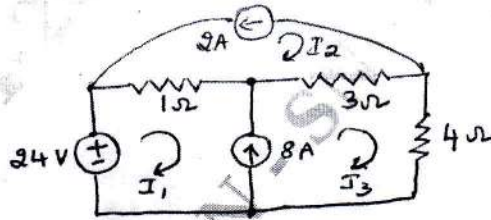

Fig. Q1 (a)

- b. Find the Thevinin's equivalent circuit shown in Fig. Q1 (b) with respect to terminals a - b.

(07 Marks)

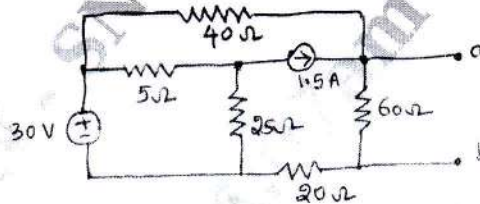

Fig. Q1 (b)

- c. Explain superposition and Thevinin's theorems.

(06 Marks)

OR

- 2 a. For the circuit shown in Fig. Q2 (a), find the voltage V_x . Use nodal analysis.

(07 Marks)

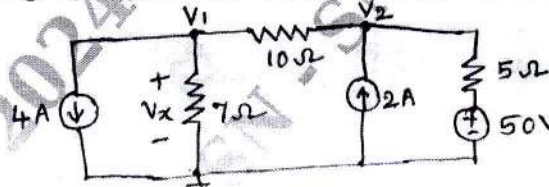

Fig. Q2 (a)

- b. State and prove maximum power transfer theorem for DC circuits.

(06 Marks)

- c. Find the maximum power dissipated in R_L shown in Fig. Q2 (c).

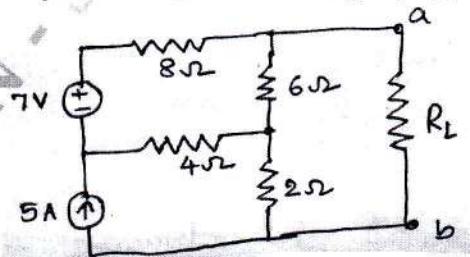

Fig. Q2 (c)

(07 Marks)

Important Note : 1. On completing your answers, compulsorily draw diagonal cross lines on the remaining blank pages.
2. Any revealing of identification, appeal to evaluator and /or equations written eg. 42+8 = 50, will be treated as malpractice.

Module-2

- 3 a. State and prove initial and final value theorems. (06 Marks)
 b. Find Laplace transform of $f(t)$ shown in Fig. Q3 (b).

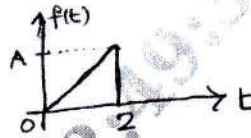

Fig. Q3 (b)

- c. Determine z-parameters for the network shown in Fig. Q3 (c).

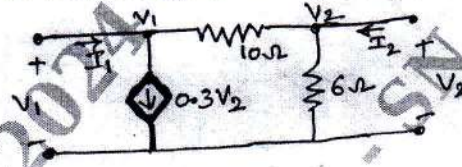

Fig. Q3 (c)

OR

- 4 a. Find Laplace transform of unit impulse, unit step and unit ramp functions. (06 Marks)
 b. For the circuit shown in Fig. Q4 (b). Find $i(t)$. Assume $V_C(0) = 10$ V and $i(0) = 0$ A.

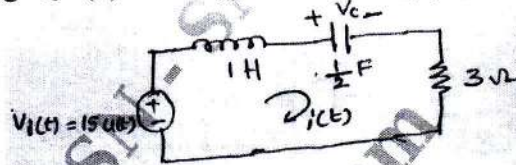

Fig. Q4 (b)

- c. Find h-parameters for the circuit shown in Fig. Q4 (c).

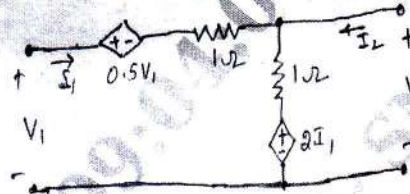

Fig. Q4 (c)

Module-3

- 5 a. For the signal flow graph shown in Fig. Q5 (a), find $\frac{C(s)}{R(s)}$ by using Mason's gain formula. (08 Marks)

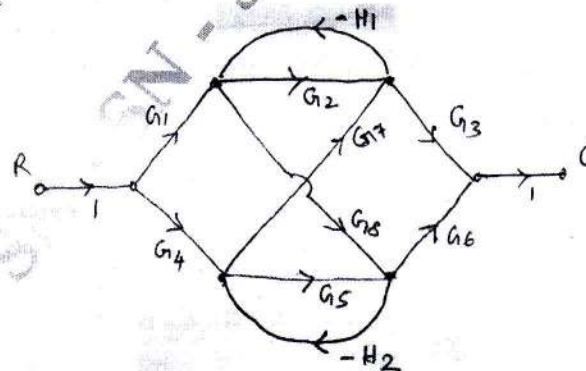

Fig. Q5 (a)

b. Explain Mason's gain formula.

(04 Marks)

c. Reduce the block diagram, shown in Fig. Q5 (c) and find $\frac{C(s)}{R(s)}$ by using block diagram reduction techniques.

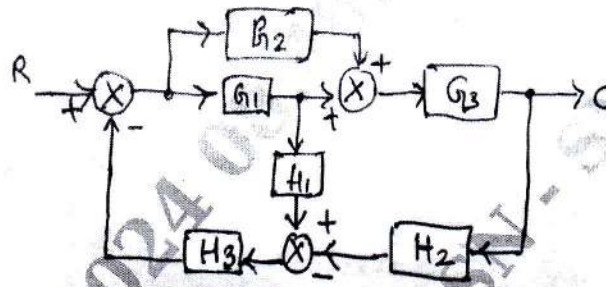

Fig. Q5 (c)

(08 Marks)

OR

6 a. Explain with a specimen signal flow graph the following :

- (i) Forward path and forward path gain.
- (ii) Loop and loop gain.
- (iii) Non touching loops.
- (iv) Input and output nodes.

(04 Marks)

b. Find $\frac{C(s)}{R(s)}$ for the signal flow graph shown in Fig. Q6 (b).

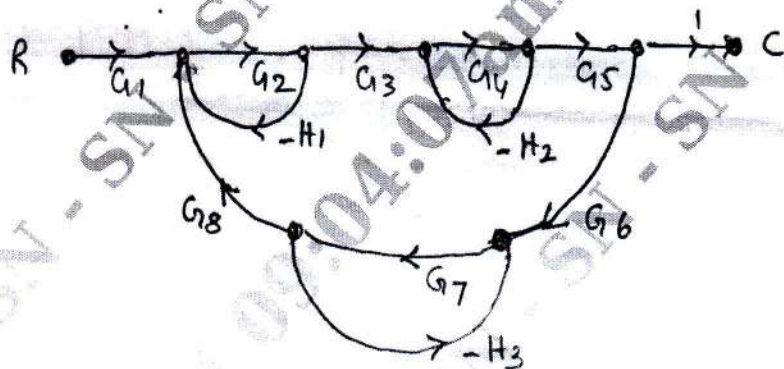

Fig. Q6 (b)

(08 Marks)

c. Find $\frac{C}{R}$ for the block diagram, shown in Fig. Q6 (c) using block diagram reduction technique.

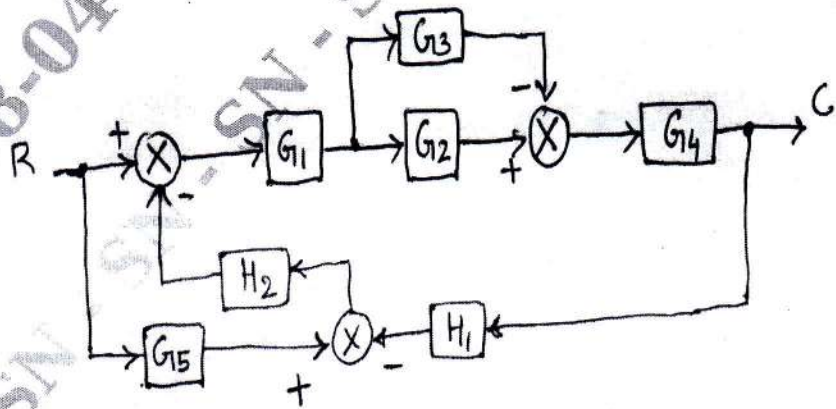

Fig. Q6 (c)

(08 Marks)

Module-4

- 7 a. Derive time-domain expression for the unit step response of a second order under damped system subjected to a unit step input. (08 Marks)
- b. A unity feedback system has an open-loop transfer function,

$$G(s)H(s) = \frac{K}{s(s+10)}$$

Find the value of K so that the system will have a damping ratio of 0.5. For this value of K, find rise time, peak time, peak overshoot and settling time corresponding to unit step response of the system. (06 Marks)

- c. Refer the characteristic equation, given below $s^4 + 25s^3 + 15s^2 + 20s + K = 0$, $K > 0$. Find the range of K for closed loop stability. Use RH criterion. (06 Marks)

OR

- 8 a. State and derive expression for t_p , M_p and t_r corresponding to unit step response of a second order under damped system. (08 Marks)

- b. A unity feedback system has an open-loop transfer function,

$$G(s)H(s) = \frac{K(1-s)}{s(s^2 + 5s + 9)}$$

Find the range of K for closed loop stability. Use RH criterion. (06 Marks)

- c. Measurements conducted on a closed loop system reveals the unit step response to be,

$$C(t) = 1 + 0.2e^{-60t} - 1.2e^{-10t}, t \geq 0.$$

- (i) Obtain the closed loop transfer function of the system (06 Marks)
- (ii) Find natural frequency and damping ratio of the system. (06 Marks)

Module-5

- 9 a. Sketch the root-locus plot, if the open loop transfer function,

$$G(s)H(s) = \frac{K(s+6)}{s(s+1)(s+2)}$$

Show all the salient points on the root locus. (12 Marks)

- b. Compute the state transition matrix for the given system matrix,

$$A = \begin{bmatrix} 1 & 0 \\ 1 & 1 \end{bmatrix} \text{ using Laplace approach. (08 Marks)}$$

OR

- 10 a. Sketch the root-locus plot for a negative feedback system having an open-loop transfer function.

$$G(s)H(s) = \frac{K}{s(s+1)(s+2)}, K > 0 \quad (12 \text{ Marks})$$

- b. Obtain the state-transition matrix of the following system:

$$\begin{bmatrix} \dot{x}_1 \\ \dot{x}_2 \end{bmatrix} = \begin{bmatrix} 0 & 1 \\ -2 & -3 \end{bmatrix} \begin{bmatrix} x_1 \\ x_2 \end{bmatrix}$$

Also, find the inverse of state-transition matrix. (08 Marks)
